

Process Control, 3P4

Assignment 5

Kevin Dunn, kevin.dunn@mcmaster.ca

Due date: 12 March 2014

This assignment is due on Wednesday, 12 March 2014. Late hand-ins are not allowed. Since it is posted mainly for you to practice for the midterm, there is no need to submit it. However, if you submit it, we will drop the assignment with the lowest grade to calculate your assignment average. So this is a way to boost your assignment portion of your overall grade.

Question 1 [5]

Many practical chemical engineering systems occur in series, for example heat exchangers, or a sequence of reactors.

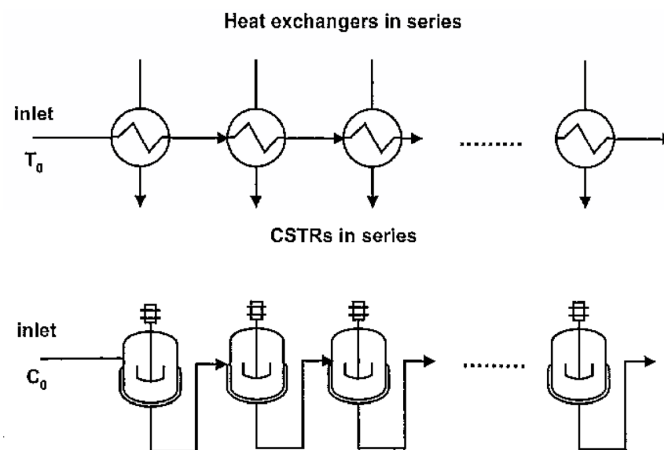

Consider tanks in series, each with a transfer function $G_{p,i}(s) = \frac{X_{i+1}(s)}{X_i(s)} = \frac{K}{\tau s + 1} = \frac{1.5}{4s + 1}$.

The X_i in this example might, for example, refer to the concentration of product leaving each reactor, in deviation form.

1. Create a Simulink model for 5 such units in series. Supply a step input of 2 units into the first tank. Plot and show the concentration leaving the last tank.
2. What is the gain of the system?
3. Not for grade, but strongly recommended because it is easy practice: use your Simulink model output from the last tank, and fit a first-order plus time delay model, $G_p = \frac{K_p e^{-\theta s}}{\tau s + 1}$ to the plotted data from part 1.

What values of process gain, K_p , process time constant, τ , and process time delay, θ , do you observe? Does the gain match the gain from part 2 of this question? What do you notice about the FOPTD time constant, τ ?

Question 2 [10]

From a previous midterm, this question is also in the next assignment.

In the process below it is desired to control the temperature of the fluid within the tank by manipulating the flow rate F_A . The temperature of stream B, T_B is expected to fluctuate. T_A and F_B , and the liquid volume in the tank are assumed constant.

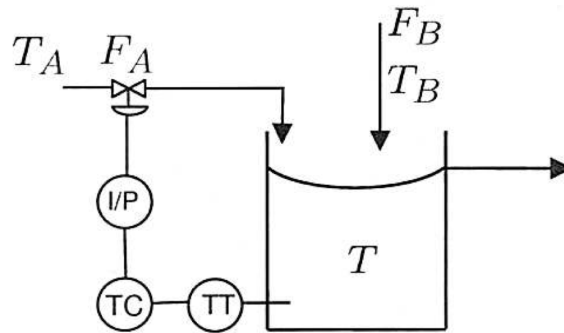

An energy balance on the tank gives: $T'(s) = \frac{18}{2s + 1}F'_A(s) + \frac{0.6}{2s + 1}T'_B(s)$

where F_A is in L/min, T and T_B are in Kelvin, and the time constant is in minutes. The true tank temperature is not what is recorded by the sensor. In fact, the measured temperature, $T_m = 0.15T$, where T_m is a signal value in milliamps, mA.

It is this measured signal, in mA, that is used to feed back and send to the controller, TC. The controller has to send a signal to the valve to open or close it. It does this by sending a signal, in mA, to the valve. This signal travels at least 1000 m across the plant network to reach the valve, which is why an electrical signal is preferred.

At the valve is an I/P transducer (search the internet for what this term means), which converts the signal to a pressure, in psig. If the I/P transducer receives a 4mA signal, it creates a 3 psig output. If it receives a 20 mA signal, it provides a 20 psig output. This pressure counteracts a spring in the valve to open or close it. The 4mA and 20mA are the lowest and highest signals possible, corresponding to the valve being fully shut and open, respectively. All other valve positions are linearly between these points.

Finally, the pressure output causes the valve to slowly open or close (i.e. it is not instantly opened or closed). When the pressure is suddenly increased by 2mA, we notice that the response in the flow rate, F_A , is a first order output, with a final value of 1 L/min higher, taking about 0.5 minutes to completely reach this increased flow.

Use the above information and draw a block diagram of all the systems described here, clearly showing the manipulated variable, disturbance, and show blocks for the temperature sensor, I/P transducer and valve. Show all units on the lines connecting the blocks.

Question 3 [10]

The following diagram is shown in Marlin’s textbook, Figure, Q6.4, page 202.

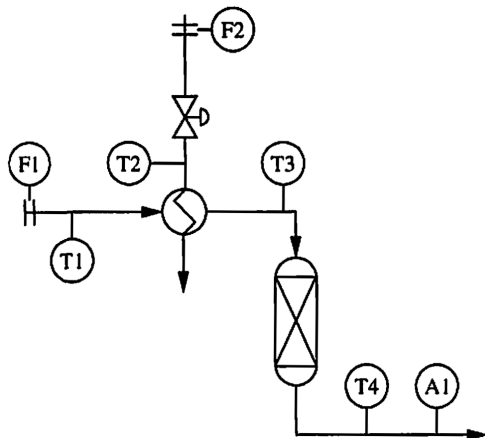

If the the valve position at F2 is opened 5% more (on the left axis), then the corresponding temperature output response at T4 is observed (right axis)

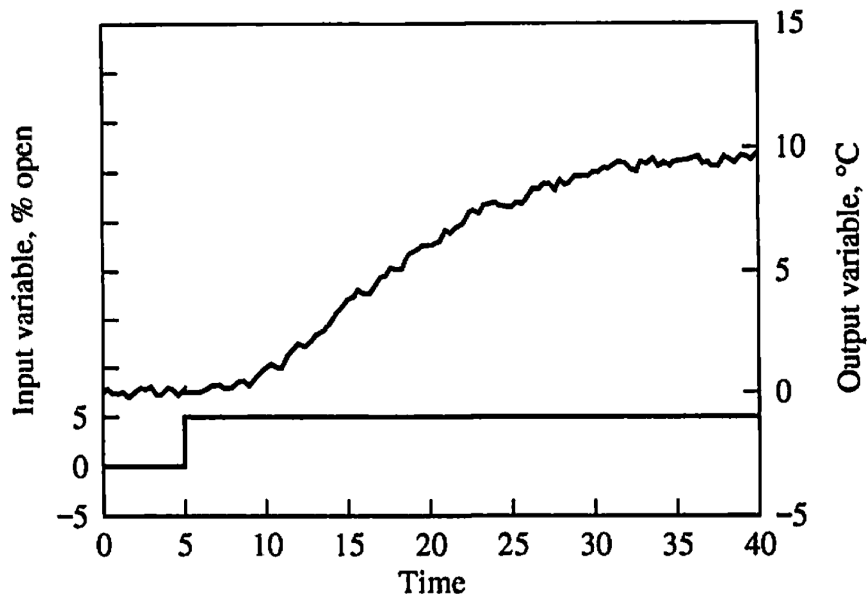

1. Explain why the response in temperature is expected. In your response report whether the reaction in the reactor is exothermic or endothermic.
2. Your goal is to control T4 to be fairly constant, by using the flow rate of F2 (i.e. the valve position just after the F2 flow meter).
List at least 5 plausible disturbances that will cause T4 to deviate from the desired set point.
3. Use the process model computed in the prior part to tune PID controllers settings K_c , T_I and T_D for a regular PID controller.

END