

Separation Processes: **Adsorption**

ChE 4M3

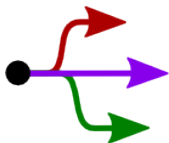

© Kevin Dunn, 2014

kevin.dunn@mcmaster.ca

<http://learnche.mcmaster.ca/4M3>

Overall revision number: 318 (November 2014)

Copyright, sharing, and attribution notice

This work is licensed under the Creative Commons Attribution-ShareAlike 4.0 International License. To view a copy of this license, please visit

<http://creativecommons.org/licenses/by-sa/4.0/>



This license allows you:

- ▶ **to share** - copy and redistribute the material in any way
- ▶ **to adapt** - but you must distribute the new result under the same or similar license to this one
- ▶ **commercialize** - you are allowed to use this work for commercial purposes
- ▶ **attribution** - but you must attribute the work as follows:
 - ▶ “Portions of this work are the copyright of Kevin Dunn”, *or*
 - ▶ “This work is the copyright of Kevin Dunn”

(when used without modification)

We appreciate:

- ▶ if you let us know about **any errors** in the slides
- ▶ **any suggestions to improve the notes**

All of the above can be done by writing to

`kevin.dunn@mcmaster.ca`

or anonymous messages can be sent to Kevin Dunn at

<http://learnche.mcmaster.ca/feedback-questions>

If reporting errors/updates, please quote the current revision number: 318

References used (in alphabetical order)

- ▶ Geankoplis, “Transport Processes and Separation Process Principles”, 4th edition, chapter 12
- ▶ Ghosh, “Principles of Bioseparation Engineering”, chapter 8
- ▶ Johnston, “Designing Fixed-Bed Adsorption Columns”, *Chemical Engineering*, p 87-92, 1972
- ▶ Lukchis, “Adsorption Systems: Design by Mass-Transfer-Zone Concept”, *Chemical Engineering*, 1973.
- ▶ **Perry's Chemical Engineers' Handbook**, 8th edition, chapter 22
- ▶ Richardson and Harker, “Chemical Engineering, Volume 2”, 5th edition, chapter 17
- ▶ Schweitzer, “Handbook of Separation Techniques for Chemical Engineers”, chapter 3.1
- ▶ Seader, Henley and Roper, “Separation Process Principles”, 3rd edition, chapter 15
- ▶ Uhlmann's Encyclopedia, “Adsorption”, [DOI:10.1002/14356007.b03.09.pub2](https://doi.org/10.1002/14356007.b03.09.pub2)
- ▶ Wankat, “Separation Process Engineering”, chapter 16

This section in context of the course

- ▶ Continuous operation
 - ▶ Sedimentation
 - ▶ Centrifuges, cyclones
 - ▶ Membranes (except periodically backflushed to regenerate)
 - ▶ filtration (e.g. vacuum filtration)
 - ▶ Liquid-liquid extraction

- ▶ Batch/cycled operation
 - ▶ filtration (e.g. plate and frame)
 - ▶ **adsorption units**
 - ▶ drying units (*next*)

Our goals

- ▶ understand what adsorbers look like and how they are operated
- ▶ how to find the equilibrium isotherms for a new system
- ▶ preliminary sizing of an adsorption unit

Introduction to sorption processes

Sorption

Components in a fluid phase, **solutes**, are selectively transferred to insoluble, (rigid) particles that are suspended in a vessel or packed in a column.

- ▶ **(ad)sorbate**: the (ad)sorbed solute that's usually of interest
- ▶ **(ad)sorbent**: the (ad)sorbing agent, i.e. the MSA
- ▶ Is there an ESA?

Some sorption processes:

- ▶ **absorption**: gas into liquid phase [it is strictly speaking a sorption process, but not considered here (3M4)]
- ▶ **adsorption**: molecules bond with a solid **surface**
- ▶ **ion-exchange**: ions displace dissimilar ions from solid phase
 - ▶ Water softening: $\text{Ca}_{(\text{aq})}^{2+} + 2\text{NaR}_{(\text{s})} \rightleftharpoons \text{CaR}_{2(\text{s})} + 2\text{Na}_{(\text{aq})}^{+}$
- ▶ **chromatography**: solutes move through column with an eluting fluid. Column is continuously regenerated.

Sorption examples

We will focus on (ad)sorption for the next few classes.

Some well-known examples:

- ▶ adsorption: charred wood products to improve water taste
- ▶ adsorption: decolourize liquid with bone char
- ▶ adsorption: those little white packets in boxes of electronics
- ▶ ion-exchange: passing water through certain sand deposits removes salt
- ▶ ion-exchange: synthetic polymer resins widely used to soften water



Industrial use of adsorption picked up with synthetic manufacturing of zeolites in the 1960s.

Adsorption examples

- ▶ Gas purification:
 - ▶ Volatile organics from a vent stream
 - ▶ Sulphur compounds from gas stream
 - ▶ Water vapour
 - ▶ Removal of CO₂ from natural gas [alternatives ?]
- ▶ Bulk separation in the gas phase:
 - ▶ O₂ from N₂ (adsorbed more strongly onto zeolites)
 - ▶ H₂O from ethanol
 - ▶ High acetone quantities from air vent streams
- ▶ Liquid-liquid separation and purification:
 - ▶ Organics and toxic compounds from water
 - ▶ Sulphur compounds from water
 - ▶ Normal vs iso-paraffin separation
 - ▶ Separation of isomers: *p*- vs *m*-cresol
 - ▶ Fructose from dextrose separation
 - ▶ Gold in cyanide solutions

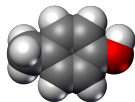

p-cresol

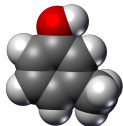

m-cresol

[Cresol figures from Wikipedia]

Adsorbents

General principle (more details coming up soon)

Molecules attach to the **particle's surface**: outside and on the pore walls

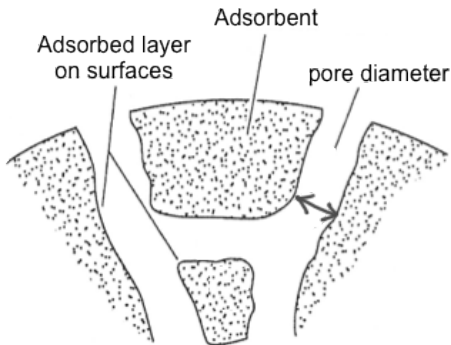

Main characterization: **pore diameter** of adsorbent

Mechanisms during adsorption

- ▶ **equilibrium interaction**: solid-fluid interactions
- ▶ **kinetic**: differences in diffusion rates
- ▶ **steric**: pore structure hinders/retains molecules of a certain shape

Quick recap of some familiar concepts

- ▶ $1\text{m} = 100\text{cm} = 1000\text{mm} = 10^6\mu\text{m} = 10^9\text{nm} = 10^{10}\text{\AA}$
- ▶ Hydrogen and helium atoms: $\approx 1\text{\AA}$
- ▶ For a pore:

$$\frac{\text{Internal surface area}}{\text{Pore volume}} = \frac{\pi d_p L}{\pi d_p^2 L / 4} = \frac{4}{d_p}$$

- ▶ d_p = pore diameter: typically around 10 to 200 \AA

Our main concern is solid's adsorption area per unit mass:

- ▶ solids are about 30 to 85% porous
- ▶ typical values: 300 to 1200 m^2 per gram
- ▶ area of hockey field = $91.4 \times 55 \text{ m} = 5027 \text{ m}^2$

Adsorbents

Helpful to see what they look like to understand the principles:



[Wikipedia, Active-Al2O3.jpg]

Activated alumina

- ▶ made from from aluminum hydroxide
- ▶ $\sim 300 \text{ m}^2$ per gram
- ▶ most widely used adsorbent
- ▶ hydrophilic
- ▶ pore diameter: 10 to 75 \AA

Adsorbents

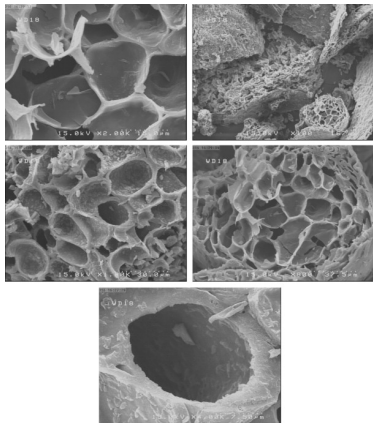

[DOI:10.1016/j.saa.2011.10.012]

Activated carbon

- ▶ partially oxidized coconut shells, nuts, wood, peat, bones, sewage sludge
- ▶ difference hardnesses of adsorbent
- ▶ 400 to 1200 m² per gram
- ▶ hydrophobic
- ▶ pore diameter: 10 to over 50Å

e.g. bone char: decolourizing syrups

Adsorbents



Molecular Sieve Type A
(a)



Molecular Sieve Type X
(b)

[Seader, 3ed, p575]

[Uhlmanns, p565]

(A)

α -Cage

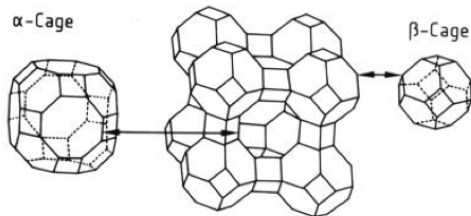

Zeolite lattices

Some examples

$K_{12}[(AlO_2)_{12}(SiO_2)_{12}]$:
drying gases [2.9Å]

$Na_{12}[(AlO_2)_{12}(SiO_2)_{12}]$:
 CO_2 removal [3.8Å]

$Ca_{43}[(AlO_2)_{86}(SiO_2)_{106}]$:
air separation [8Å]

Very specific pore diameters.

- ▶ 40 naturally occurring
- ▶ ~ 150 synthesized
- ▶ ~ 650 m² per gram

Adsorbents

Zeolites; also called **molecular sieves**

Window size	Adsorbs...	Dehydrates ...
3Å	H ₂ O, NH ₃	unsaturated hydrocarbons
4Å	H ₂ S, CO ₂ , C ₃ H ₆	saturated hydrocarbons
5Å	<i>n</i> -paraffins from iso-paraffins	
8Å	iso-paraffins and olefins	

[Johnston]

Electrostatic fields exist inside the zeolite cage: strong interactions with polar molecules. Sieving not only based on shape/size exclusion.

[Rousseau, "Handbook of Separation Technology"]

Adsorbent	Market size (1983)
Activated carbon	\$ 380 million ← 25% for water treatment
Molecular-sieve zeolites	\$ 100 million
Silica gel	\$ 27 million
Activated alumina	\$ 26 million

Pore diameter characterization

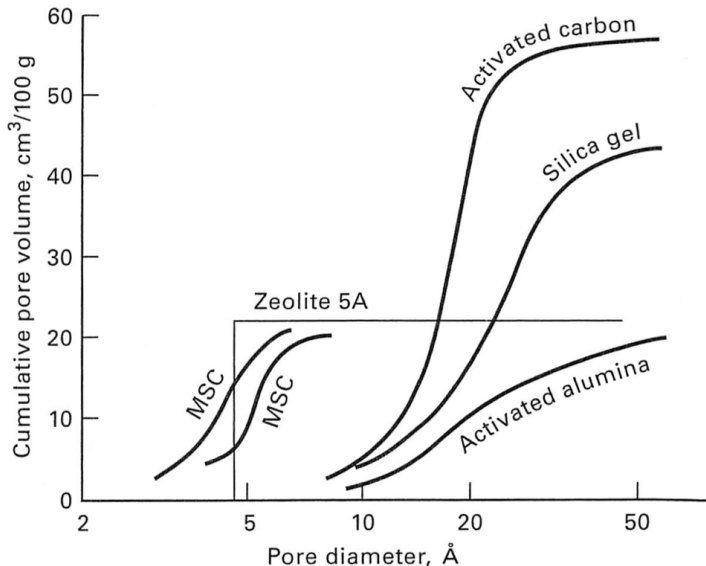

Example: Gold leaching and adsorption

- ▶ Crushed rock has gold particles exposed
- ▶ Leaching:
$$4\text{Au}_{(s)} + 8\text{NaCN} + \text{O}_2 + 2\text{H}_2\text{O} \rightleftharpoons 4\text{Na}[\text{Au}(\text{CN})_2] + 4\text{NaOH}$$
- ▶ Adsorption: aurocyanide complex, $\text{Au}(\text{CN})_2^-$, is adsorbed onto activated carbon
 - ▶ drives the equilibrium in the leaching step forward
 - ▶ separates the solid gold, $\text{Au}_{(s)}$, from the pulp (slurry)
 - ▶ obtain $C_{A,S} \sim 8000$ grams of Au per tonne of carbon
- ▶ Desorption:
 - ▶ separate the highly concentrated gold-carbon pulp (screens/filter/cyclones/sedimentation)
 - ▶ desorb the gold off the carbon with caustic contact
 - ▶ recycle the regenerated carbon

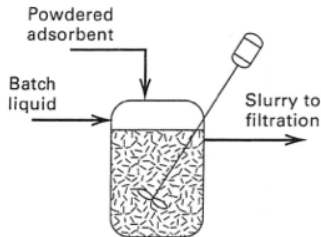

Gold leaching: Johannesburg, RSA

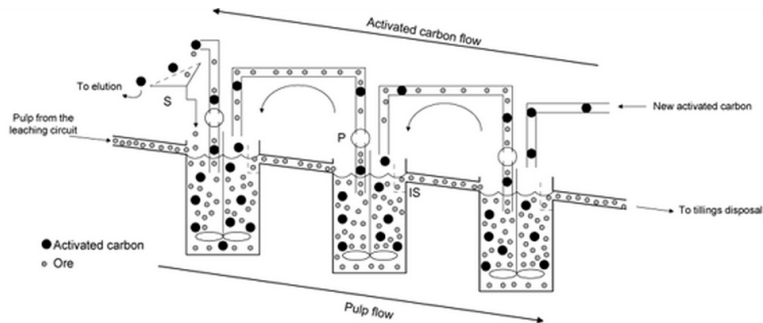

H₂S and CO₂ pre-treatment adsorbers



When to consider adsorption

Distillation, membranes, absorption, liquid-liquid extraction are sometimes viable alternatives.

But adsorption is considered when:

- ▶ relative volatility between components is < 1.5 (e.g. isomers)
- ▶ large reflux ratios would be required
- ▶ too large area for a membrane
- ▶ excessive temperatures or high pressure drops are to be avoided
- ▶ high selectivity is required
- ▶ feed is a very dilute stream of solute (adsorbate)

But, some disadvantages:

- ▶ only the surface of the adsorbent used
- ▶ regeneration of MSA adsorbent required
- ▶ MSA will break down mechanically over time as we move it around
 - ▶ we often have to pump them, filter them, and/or put them through cyclones to process the solid phase

Physical principles

Adsorption releases heat, it's exothermic. Why?

Loss of degrees of freedom of fluid: free energy is reduced, so $\Delta S \downarrow$

$$\Delta G = \Delta H - T\Delta S \implies \Delta H = \Delta G + T\Delta S \implies \Delta H < 0$$

Two types of adsorption:

1. Physical adsorption (**physisorption**):

- ▶ Low heat of adsorption released: $\Delta H_{\text{ads}} \sim 30$ to 60 kJ/mol
- ▶ Theory: **van der Waals attractions**
- ▶ easily reversible

2. Chemical adsorption (**chemisorption**):

- ▶ High heat of adsorption released: $\Delta H_{\text{ads}} > 100$ kJ/mol
- ▶ chemical bond formation, in the order of chemical bond strengths
- ▶ leads to reaction products
- ▶ more energy intensive to reverse
- ▶ e.g.: catalysis, corrosion

As adsorbate concentration increases:

- ▶ single layers form, then multiple layers, then condensation

Packed beds: adsorption and desorption steps

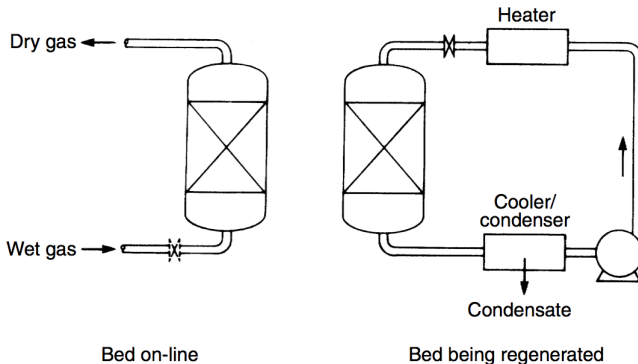

[Richardson and Harker, p 1028]

Regeneration reverses the adsorbate-adsorbent equilibrium:

1. **raise the temperature** to shift the equilibrium constant
2. **lower the pressure** (vapour-phase adsorbate)
3. displace the adsorbate with an alternative (e.g. steam)

Regenerate is shorter duration when done in the reverse direction to loading.

Fluidized beds: for continual operation

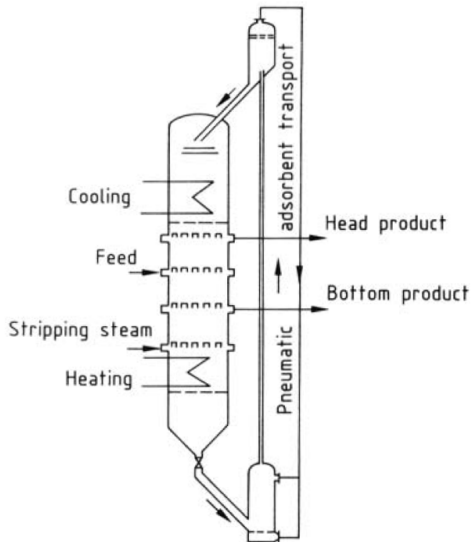

Materials of construction are important: carbon on carbon steel has a galvanic effect: leads to corrosion. Use stainless steel, or a lined vessel.

Cyclones used to recover adsorbent.

- ▶ Adsorbent life: ~ 100 cycles
- ▶ Bleed off old adsorbent and continuously replenish

(Fluidized bed?) example

Adsorption, Desorption and Recovery (ADR) plant in Burkina Faso



[[Flickr #5043854546](#)] *Zoom in on the high resolution photo to see details.*

Modelling the adsorption process

1. Diffusion

- ▶ diffusion of the adsorbate in the bulk fluid (usually very fast)
- ▶ diffusion of the adsorbate to the adsorbent surface through the boundary layer
- ▶ diffusion of the adsorbate into the pore to an open site
 - ▶ steric (shape) effects may be an issue

2. Equilibrium considerations

- ▶ adsorbate will attach to a vacant site
- ▶ adsorbate will detach from an occupied site

Mechanisms during adsorption

- ▶ **equilibrium interaction**: solid-fluid interactions
- ▶ **kinetic**: differences in diffusion rates (if multiple adsorbates)
- ▶ **steric**: pore structure hinders/retains molecules of a certain shape

Equilibrium modelling

Why?

We ultimately would like to determine **how much adsorbent is required** to remove a given amount of adsorbate (e.g. impurity); particularly in batch processes.

For now, assume we are only limited by equilibrium [we'll get there, we don't mind *how long* (due to kinetics of diffusion and mass transfer resistance) it takes to get there]

- ▶ Derive/Postulate a model relating bulk concentration to surface concentration of adsorbate
- ▶ We call these equilibrium equations: “isotherms”
- ▶ **Isotherm**: relates amount of adsorbate on adsorbent ($C_{A,S}$) at different concentrations of adsorbate in the bulk (C_A), but at a fixed temperature.

Equilibrium modelling: linear model

Linear isotherm (Henry's law)

$$C_{A,S} = KC_A$$

$$C_{A,S} = \frac{KP_A}{RT} = K'P_A$$

- ▶ $C_{A,S}$ = concentration of adsorbate A on adsorbent surface $\left[\frac{\text{kg adsorbate}}{\text{kg adsorbent}} \right]$
- ▶ C_A = concentration of adsorbate A in the bulk fluid phase $\left[\frac{\text{kg adsorbate}}{\text{m}^3 \text{ fluid}} \right]$
- ▶ P_A = partial pressure of adsorbate A in the bulk fluid phase [atm]
- ▶ K and K' are temperature dependent equilibrium constants (should be clear why)
- ▶ R is the ideal gas constant
- ▶ T is the system temperature
- ▶ Few systems are this simple!

Batch system example (*previous midterm question*)

You are to design a batch adsorber to remove an organic contaminant (A) from 400L of aqueous solution containing 0.05g/L of the contaminant. To facilitate this you do a bench scale experiment with 1L solution at the same concentration (0.05g/L) and 3g of an adsorbent. In the bench scale experiment you find that 96% of the contaminant was removed. You need to remove 99% of the contaminant in the full scale apparatus. You can assume that a linear isotherm applies.

For the full scale system:

1. At the end of the batch, what will be the concentration of the solution in the adsorber and concentration of A on the adsorbent?
2. How much adsorbent do you need? [Ans: 4.95 kg]

Equilibrium modelling: Freundlich model

Freundlich isotherm

$$C_{A,S} = K (C_A)^{1/m} \quad \text{for } 1 < m < 5$$

- ▶ It is an empirical model, but it works well

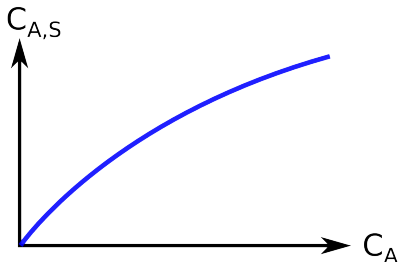

- ▶ Constants determined from a log-log plot
- ▶ How would you go about setting up a lab experiment to collect data to calculate K ?
- ▶ Which way will the isotherm shift if temperature is increased?

Equilibrium modelling: Langmuir isotherm

- ▶ we have a uniform adsorbent surface available (all sites equally attractive)
- ▶ there are a total number of sites available for adsorbate A to adsorb to
- ▶ $C_T =$ total sites available $\left[\frac{\text{mol sites}}{\text{kg adsorbate}} \right]$
- ▶ $C_V =$ vacant sites available $\left[\frac{\text{mol sites}}{\text{kg adsorbate}} \right]$
- ▶ rate of adsorption $= k_A P_A C_V =$ proportional to number of collisions of A with site S
- ▶ $C_{A,S} =$ sites occupied by A $\left[\frac{\text{mol sites}}{\text{kg adsorbate}} \right]$
- ▶ assuming 1 site per molecule of A, and only a monolayer forms
- ▶ rate of desorption $= k_{-A} C_{A,S} =$ proportional to number of occupied sites
- ▶ net rate $= k_A P_A C_V - k_{-A} C_{A,S}$

Equilibrium modelling: Langmuir isotherm

- ▶ Net rate = $k_A P_A C_V - k_{-A} C_{A,S}$
- ▶ define $K_A = \frac{k_A}{k_{-A}}$
- ▶ essentially an equilibrium constant: $A + S \rightleftharpoons A \cdot S$
- ▶ at equilibrium, the net rate is zero
- ▶ implying $\frac{k_A C_{A,S}}{K_A} = k_A P_A C_V$
- ▶ but total sites = $C_T = C_V + C_{A,S}$
- ▶ so $\frac{k_A C_{A,S}}{K_A} = k_A P_A (C_T - C_{A,S})$
- ▶ simplifying: $C_{A,S} = K_A P_A (C_T - C_{A,S})$

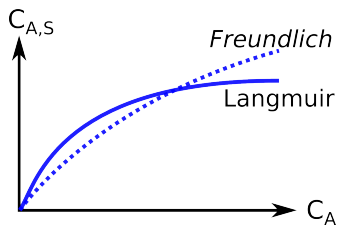

- ▶ then
$$C_{A,S} = \frac{K_A C_T P_A}{1 + K_A P_A} = \frac{K_1 P_A}{1 + K_2 P_A} = \frac{K_3 C_A}{1 + K_4 C_A}$$
- ▶ Fit data using **Eadie-Hofstee diagram** or nonlinear regression
- ▶ Same structure as Michaelis-Menten model (bio people)

Summary of isotherms

We aren't always sure which isotherm fits a given adsorbate-adsorbent pair:

1. Perform a laboratory experiment to collect the data
2. Postulate a model (e.g. linear, or Langmuir)
3. Fit the model to the data
4. Good fit?

Other isotherms have been proposed:

- ▶ BET (Brunauer, Emmett and Teller) isotherm
- ▶ Gibb's isotherm: allows for a multilayer of adsorbate forming

These are far more flexible models (more parameters); e.g. Langmuir isotherm is a special case of the BET isotherm.

Further questions to try

Adapted from Geankoplis question 12.2-1

2.5 m³ of wastewater solution with 0.25 kg phenol/m³ is mixed with 3.0 kg granular activated carbon until equilibrium is reached. Use the following isotherm, determined from lab values, to calculate the final equilibrium values of phenol extracted and percent recovery. Show the operating point on the isotherm. Units of C_A are [kg per m³] and $C_{A,S}$ is in [kg solute per kg of activated carbon].

[Ans: $C_A \approx 0.10$ kg per m³, $C_{A,S} \approx 0.12$ kg/kg, recovery = 58%]

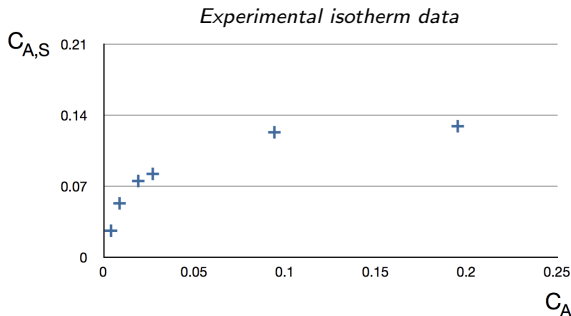

$$C_{A,S} = \frac{0.145C_A}{0.0174 + C_A}$$

Isotherms change at different temperatures

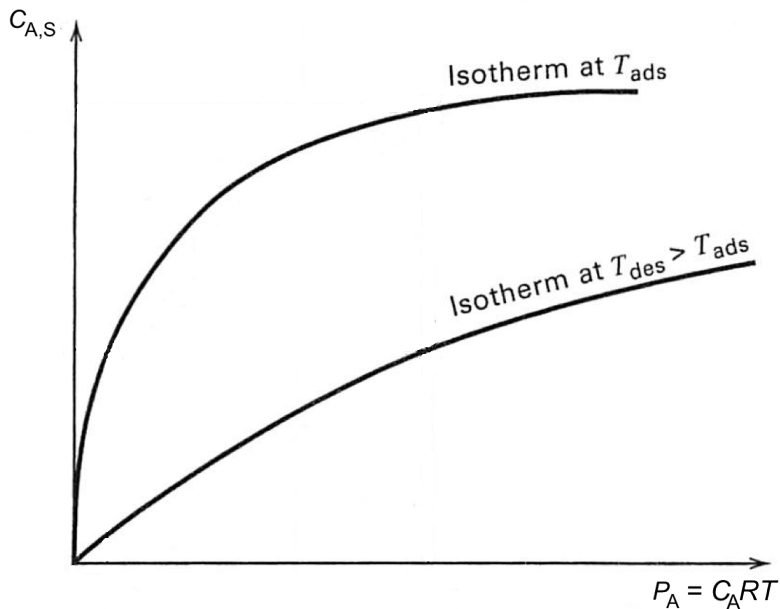

Understanding adsorption in packed beds (1 of 2)

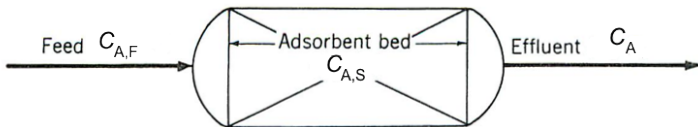

Time

Analysis of Adsorbent
(Adsorbent loading vs. bed length)

Analysis of Effluent
(Concentration of sorbable
component vs. time)

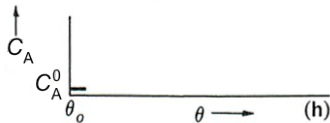
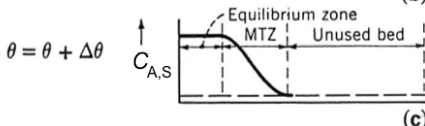
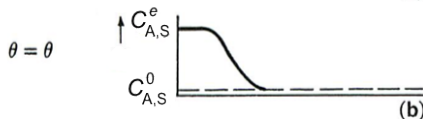

$L =$ length; $\theta =$ time; $\theta_0 =$ start-up time on a regenerated bed

Understanding adsorption in packed beds (2 of 2)

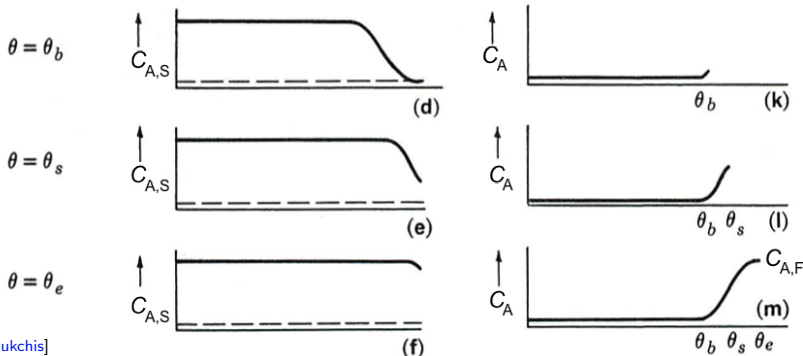

[Lukchis]

- ▶ $C_{A,S}$ = concentration of adsorbate on adsorbent
- ▶ $C_{A,S}^e$ = concentration at equilibrium on the adsorbent (equil loading)
- ▶ $C_{A,S}^0$ = concentration on the regenerated adsorbent at time 0
- ▶ θ_b = breakthrough time: "time to stop using the packed bed!"; usually when $C_A = 0.05C_{A,F}$
- ▶ θ_e = the bed at equilibrium time; packed bed is completely used
- ▶ $C_{A,S}$ values are not easy measured; outlet concentration C_A is easy

Bed concentration just prior to breakthrough

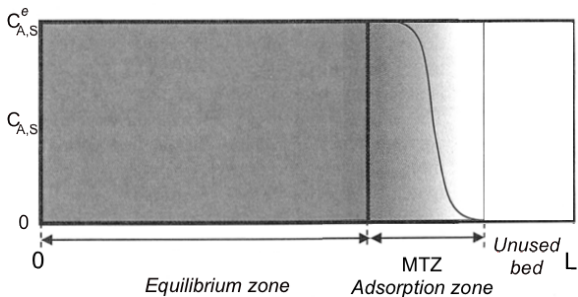

[Ghosh (adapted), p144]

- ▶ **MTZ**: mass transfer zone is where adsorption takes place.
- ▶ It is S-shaped: indicates there is mass-transfer resistance and axial dispersion and mixing. Contrast to the ideal shape: is a perfectly vertical line moving through the bed
- ▶ **Equilibrium zone**: this is where the isotherm applies!
- ▶ **Breakthrough**: arbitrarily **defined as time** when either (a) the lower limit of adsorbate detection, or (b) the maximum allowable adsorbate in effluent leaves the bed. Usually around 1 to 5% of $C_{A,F}$.

Figures to help with the next example

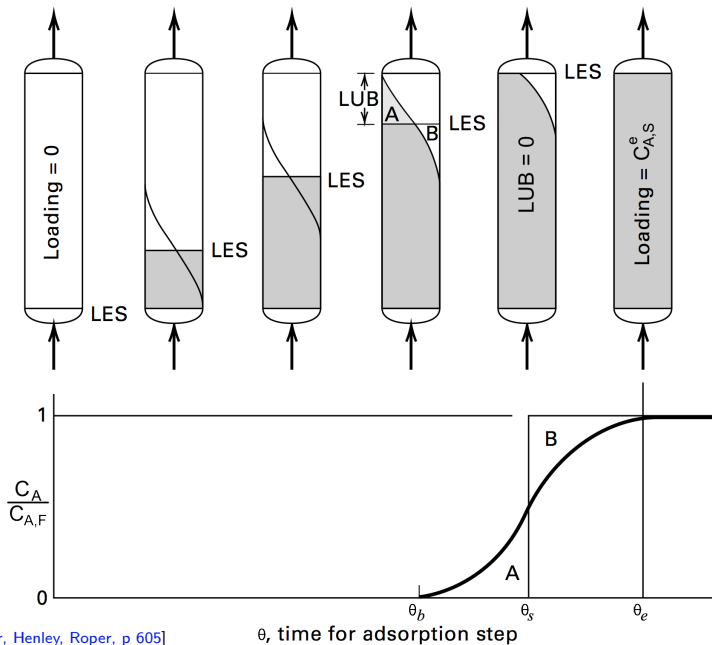

Terminology

- ▶ **LES** = length of equilibrium section (increases as bed is used)
- ▶ **LUB** = length of unused bed (decreases as bed is used up)
- ▶ L = total bed length = LES + LUB
- ▶ No data available: use MTZ distance of 4ft

Regenerating the bed

Aim

To remove adsorbate from the packed bed.

1: Temperature swing adsorption (TSA)

- ▶ heat the bed: usually steam is used (due to high latent heat)
 - ▶ why add heat? (recall, heat is released during adsorption)
- ▶ creates a thermal wave through the packed bed
- ▶ isotherm at higher temperature is shifted down
- ▶ causes the adsorbate to be diluted in the stripping fluid
- ▶ often leave some residual adsorbate behind, since time to completely strip adsorbent of it would be excessive
- ▶ care must be taken with flammable adsorbates:
 - ▶ stripping temperatures are high
 - ▶ often near flammable limits
 - ▶ carbon beds have been known to catch fire

See illustration on next page to understand TSA

Regenerating the bed

2. Pressure swing adsorption (PSA)

- ▶ used when the “product” is the cleaned (stripped) fluid
- ▶ add feed with adsorbate at high pressure (loads the adsorbate)
- ▶ drop the pressure and the adsorbate starts to desorb
- ▶ run two beds in parallel (one desorbing, the other adsorbing)
- ▶ widely used for portable oxygen generation, H_2S capture in refineries

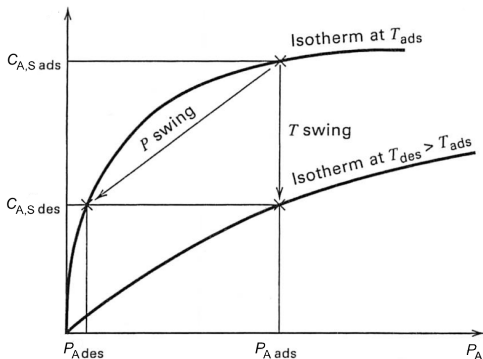

Rotary devices: to avoid a separate regeneration

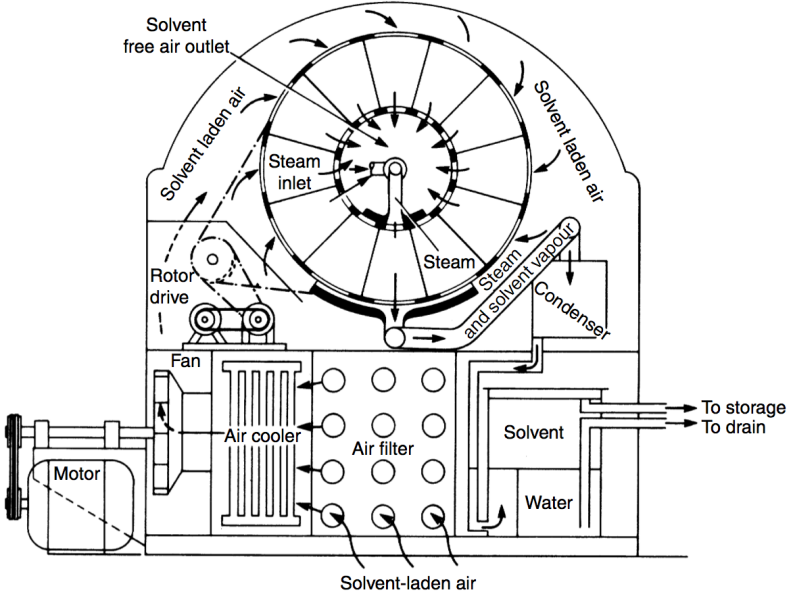

[Richardson and Harker, p 1034]

Adsorption equipment: Sorbex column

Bed remains stationary (minimizes adsorbent damage); fluid phase is pumped around.
Simulates a counter-current movement of solid to liquid.

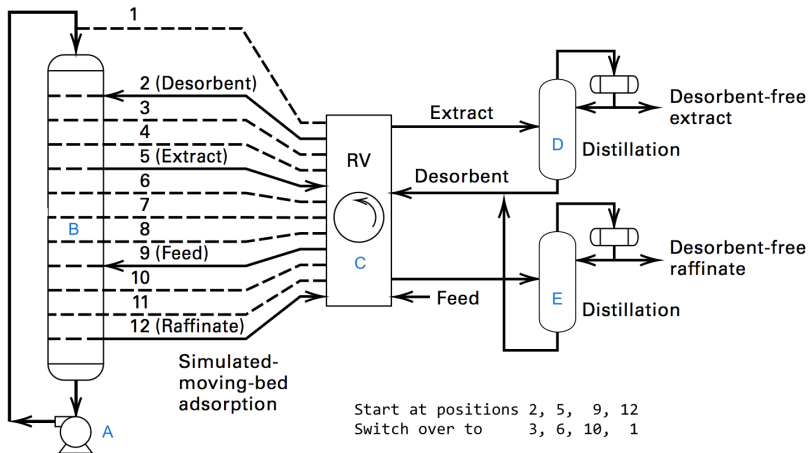

[Seader, Henley, Roper, p 611]

A) Pump; B) Adsorbent chamber; C) Rotary valve; D) Extract column; E) Raffinate column