

# Separation Processes, 4M3

## Written midterm, 15 October 2014

Kevin Dunn, kevin.dunn@mcmaster.ca

McMaster University

### Note:

- You may bring in any materials to the midterm; any textbooks, any papers, *etc.*
- You may use any calculator during the midterm, but other electronic devices (e.g. phones, tablets, laptops) may not be used.
- Do not use red pen anywhere in your answer booklet.
- This test requires that you apply the material you have learned here in 4M to new, unfamiliar situations, which is the level of thinking required from 4th and 5th year students.
- **Total marks:** 70 marks, 15% of course grade. There are 4 pages on the exam, please ensure your copy is complete.
- Total time: 2 hours. *Check your pacing: time management is critical in this test.*
- **If anything seems unclear, or information appears to be incomplete, please make a reasonable assumption and continue with the question.**
- Define, Explore, Plan, Do, Check and Generalize.

### Question 1 [20]

You are responsible for a small  $0.9 \text{ m}^2$ , but important, filtration step in the flowsheet. A feedback control loop in the process keeps the plate-and-frame press operation at  $-\Delta P = 420 \text{ kPa}$ . The materials being separated are water from solids, and this enters roughly at a concentration of  $24 \frac{\text{kg}}{\text{m}^3 \text{ filtrate}}$ .

1. Describe, with a sequence of 5 to 10 numbered bullet points, a complete set of experiments for your lab technician and how he is to acquire the right data, and then calculate the specific cake resistance:  $\alpha = \alpha_0(-\Delta P)^f$  for a given pressure difference,  $-\Delta P$ .

Ensure your description is unambiguous, so that anyone can follow your instructions to calculate  $\alpha_0$  and  $f$ . You may use illustrations in your answer. [8]

2. The experiments yield an equation for specific cake resistance as  $\alpha = 5.2 \times 10^9(-\Delta P)^{0.24}$ , where  $\alpha$  has units of  $\text{m.kg}^{-1}$ , and  $-\Delta P$  is in Pascals.

How long will it take to acquire  $7 \text{ m}^3$  of filtrate? [7]

3. That answer is obviously unacceptable for a practical filtration unit.
  - (a) What single parameter can you consider changing on the system to acquire the filtrate at least 100 times faster? Note: no equipment has been purchased yet, so you can adjust capital *or* operating costs. [2]
  - (b) Show your calculations to prove the newer system delivers filtrate at the faster rate. [4]

## Question 2 [21]

Provide short answers to these questions:

1. Microfiltration, permeate, retentate are terms associated with \_\_\_\_\_ (type of separator). [1]
2. We used Stokes' law many times to derive equations for various solid-fluid separators. Under which condition is it applicable, and show the equation for this condition (describing all terms in the equation, with their units)? [3]
3. Membrane fouling can deteriorate a membrane's performance. List 3 measures that can be implemented to counteract these problems. [3]
4. For constant pressure filtration in a batch filtration unit, draw an expected plot shape of the volume of filtrate collected ( $y$ -axis) against time ( $x$ -axis). Give the equation that substantiates the shape of your plot. [2]
5. If a sedimentation tank has a separation factor of 1000, and a centrifuge has a separation factor of 1500, ignoring economics for a moment, which is the better option? Explain your answer. [2]
6. If a sedimentation tank has a separation factor of 1000, and a centrifuge has a separation factor of 1500, describe which economic factors you now also take into account to evaluate and compare the two options. [3]
7. Give two criteria (and explain them), that will influence your decision to use a centrifuge instead of a membrane for a given separation. [3]
8. There are many separation examples that are important and benefit everyone living on our planet (as opposed to certain separation examples which benefit a company and their profitability). Name two such separation applications, and for each one indicate: [4]
  - what suitable equipment can be used,
  - what the ESA and/or MSA is,
  - and indicate which species are being separated from each other.

## Question 3 [18]

The following flowsheet shows a typical arrangement of cyclones that you would see in the mining industry. Ore consisting of gangue (sand) plus valuable minerals enters as the feed to cyclone 1 from the upstream crushers. The "crushers" step in the flowsheet is actually a sequence of many units that guarantee the material leaving has a particle size so that the largest particles lie between a number 230 and a number 200 Tyler mesh. Cyclone 1 has an Euler number of 500, and cyclone 2 has an Euler number of 500. Both cyclones have a diameter of 1.0 meter.

For example, in the gold mining industry, the aim is to achieve small ore particles, e.g.  $< 75\mu\text{m}$ , so the gold crystals are exposed on the outer surface. Later these particles are placed into in a downstream solution of cyanide which dissolves (leaches out) the exposed gold from the ore. Give your answers below in the context of this example.

1. What is the approximate size of the largest particles (reported in microns) for the material leaving the "crushers" step? [2]

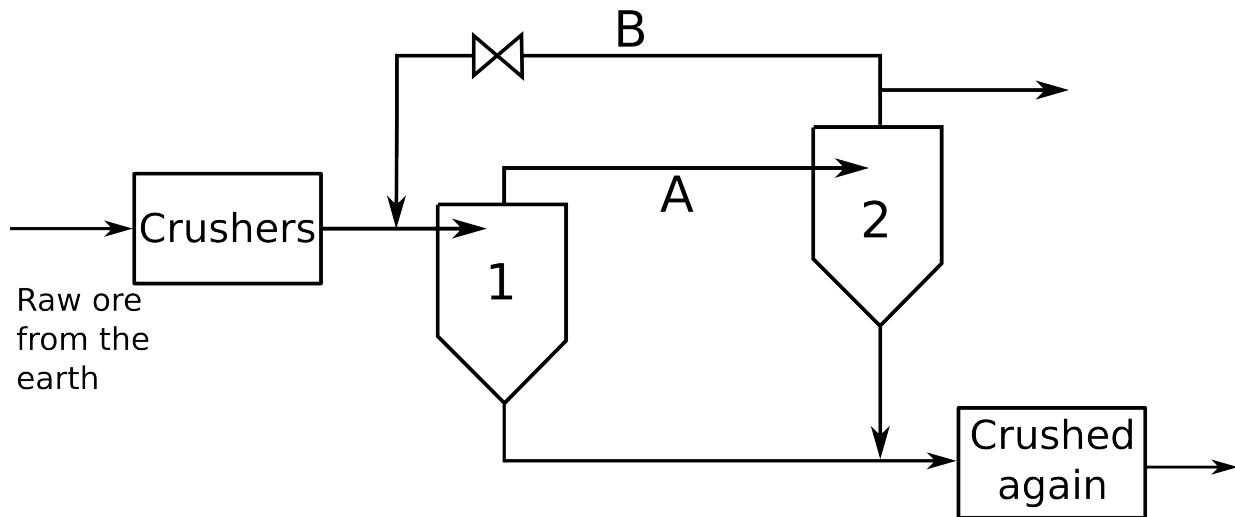

2. Assume the flow in stream B is zero (i.e. the valve in stream B is fully shut). What is the purpose of connecting cyclone 1 and 2 in series, using the connector stream A? [3]
3. Draw, on a single plot, the grade efficiency curve of
  - (a) cyclone 1,
  - (b) cyclone 2, and
  - (c) the combination of cyclone 1 and 2 when connected with stream A (stream B is off).

In other words, your grade efficiency curve must have 3 lines on it.

Clearly explain your thinking for each of the 3 curves. [5]

4. Now consider cyclones 1 and 2 connected with connection stream A, and in addition, the connector/recycle stream B is activated (e.g. you open the valve in stream B).

Explain the purpose of stream B. [2]

5. Cyclone 2 is operated with a water-solids mixture entering, and the supplier indicates the pressure drop should be between 500 and 1200 Pa for this unit. You wish to maximize the throughput:

- (a) Should you operate the cyclone at 500 or 1200 Pa? Explain your answer. [2]
- (b) What would be the expected throughput you would achieve at the pressure drop you selected? Report your answer in  $L.min^{-1}$ . [4]

Turn over ...

#### Question 4 [11]

This flowsheet is from the MIT OpenCourseware website, “Separation Processes for Biochemical Products”, taught in 2005. It shows the steps for recovery of alkaline protease, a biological enzyme, which is recovered downstream in the retentate.

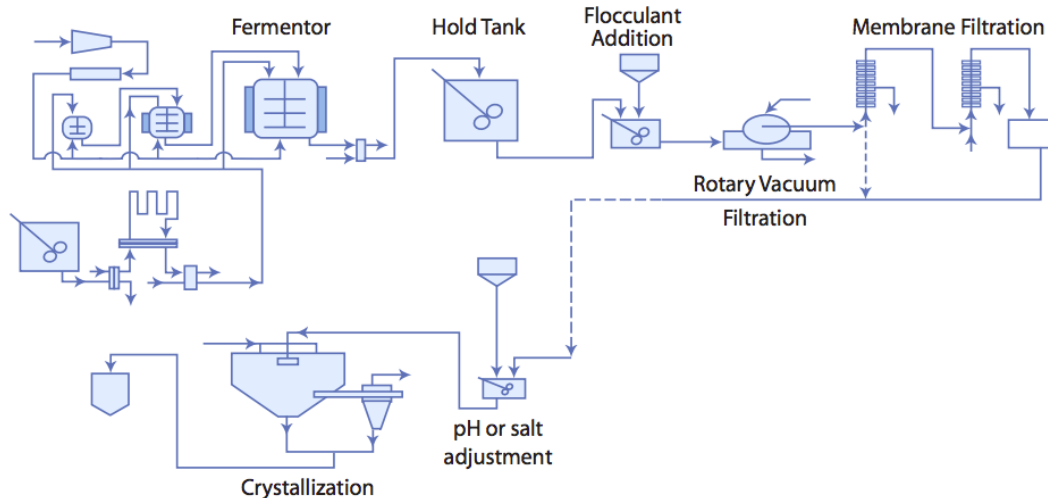

You can view these lecture notes at [http://ocw.mit.edu/courses/chemical-engineering/10-445-separation-processes-for-biochemical-products-summer-2005/lecture-notes/lecture\\_10.pdf](http://ocw.mit.edu/courses/chemical-engineering/10-445-separation-processes-for-biochemical-products-summer-2005/lecture-notes/lecture_10.pdf) after the midterm (they tie in nicely with 4N4, since the slides consider various economic aspects of these biological flowsheets).

1. Give clear reasons why flocculation is applied (in general)? [2]
2. Name a chemical compound that is used as a flocculant for municipal wastewater treatment. [1]
3. How does the flocculation step modify the subsequent filtration step's behaviour? Be specific, and use equations to clearly justify what flocculation is achieving. [5]
4. From after the holding tank, to just before “pH or salt adjustment” in the flowsheet: indicate if each of the units operates continuously, or in a batch mode. Explain your answer [3]

---

**The end.**